

18

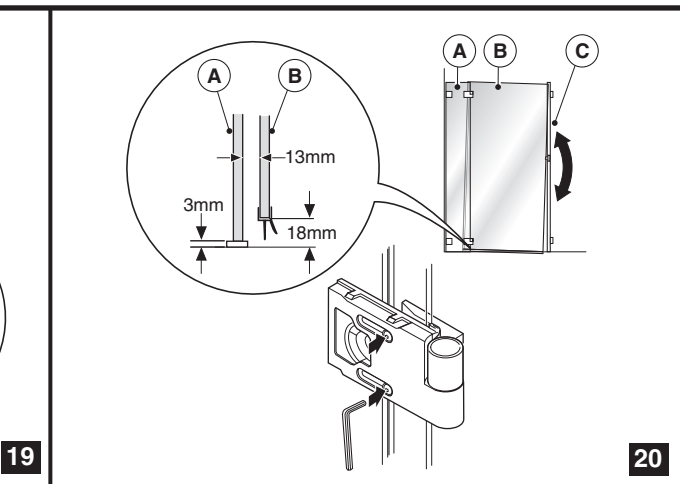

19

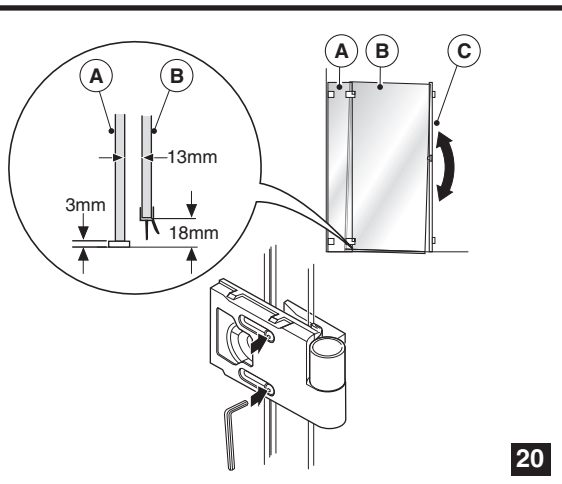

20

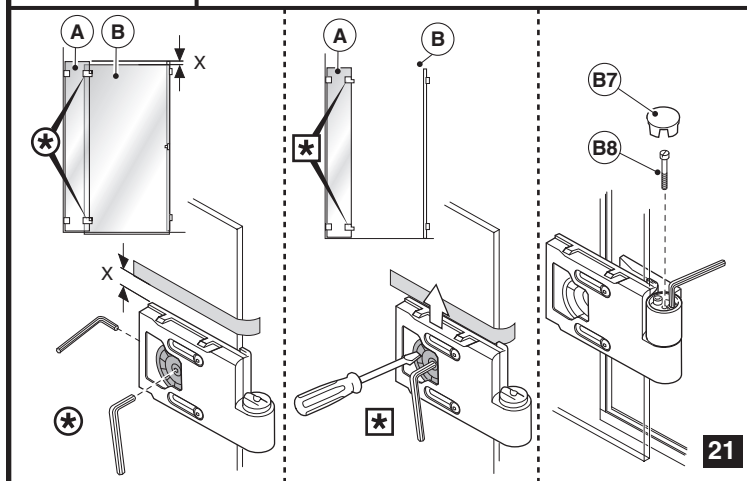

21

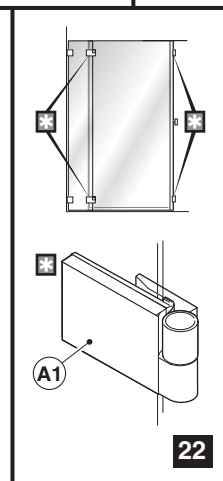

22

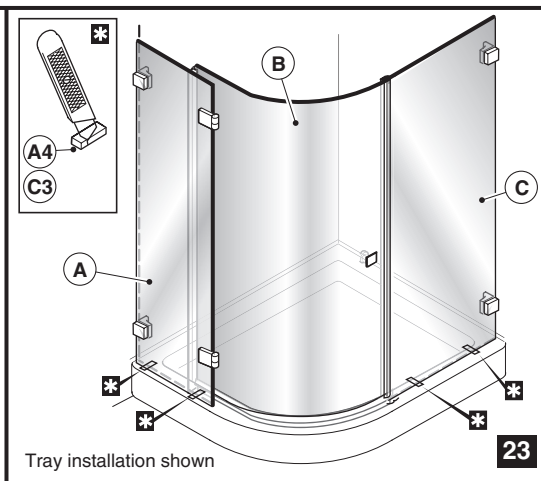

23

Tray installation shown

SEALING THE ENCLOSURE

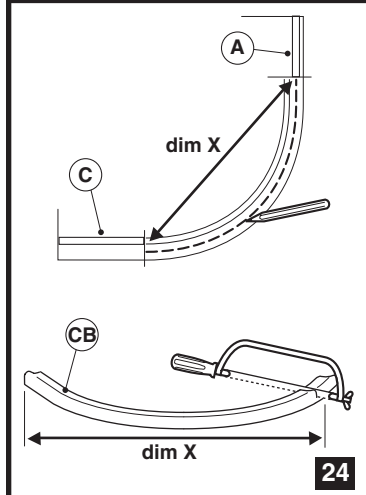

24

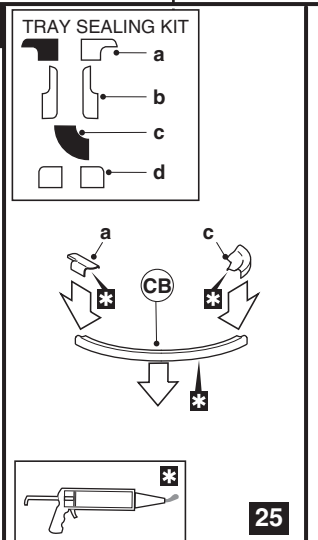

25

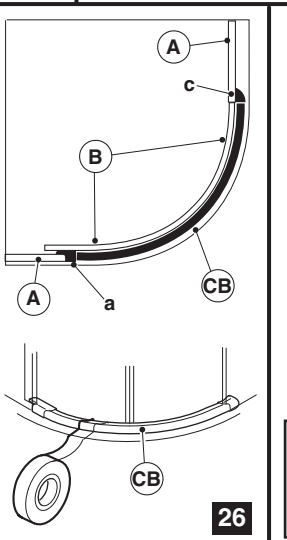

26

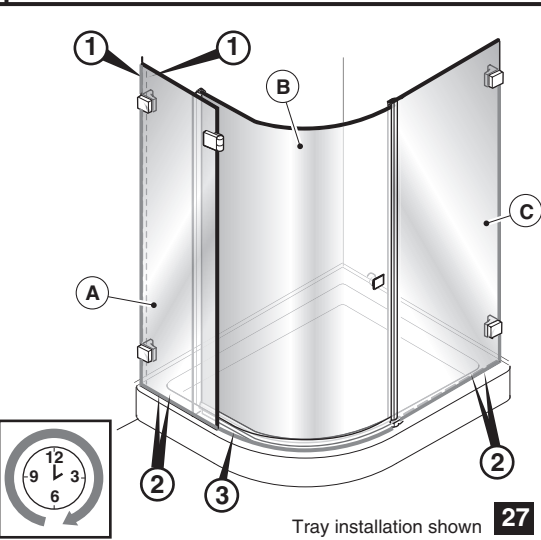

27

Tray installation shown

SUPPORT BRACKET

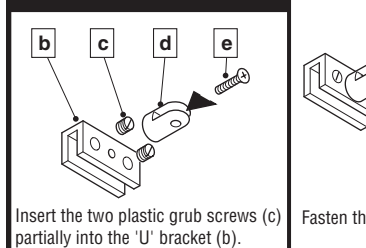

Insert the two plastic grub screws (c) partially into the 'U' bracket (b).

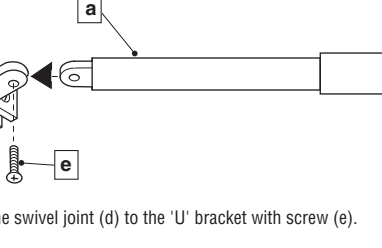

Fasten the swivel joint (d) to the 'U' bracket with screw (e).

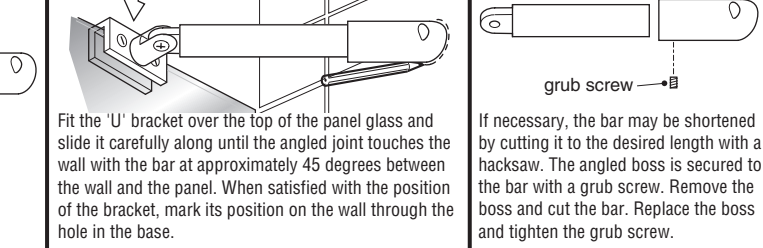

Fit the 'U' bracket over the top of the panel glass and slide it carefully along until the angled joint touches the wall with the bar at approximately 45 degrees between the wall and the panel. When satisfied with the position of the bracket, mark its position on the wall through the hole in the base. If necessary, the bar may be shortened by cutting it to the desired length with a hacksaw. The angled boss is secured to the wall with a grub screw. Remove the boss and cut the bar. Replace the boss and tighten the grub screw.

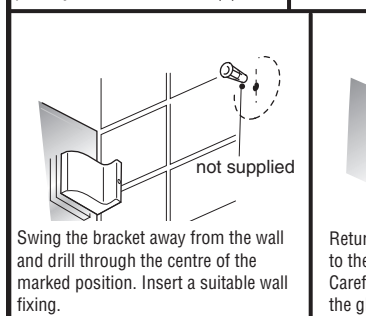

Swing the bracket away from the wall and drill through the centre of the marked position. Insert a suitable wall fixing.

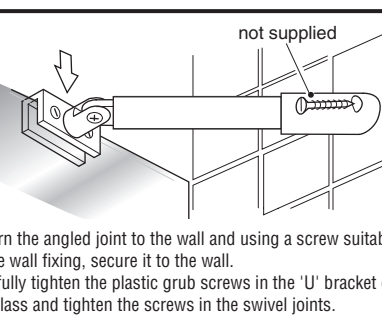

Return the angled joint to the wall and using a screw suitable to the wall fixing, secure it to the wall. Carefully tighten the plastic grub screws in the 'U' bracket onto the glass and tighten the screws in the swivel joints.

CARE AND ATTENTION

Clean your enclosure with mild detergent and water promptly after use. This will prevent the build up of limescale.

NEVER use an abrasive or aggressive cleaner. A proprietary glass cleaner can be used if necessary.

CONTENTS

FIXED PANEL

* these items located in the door pack

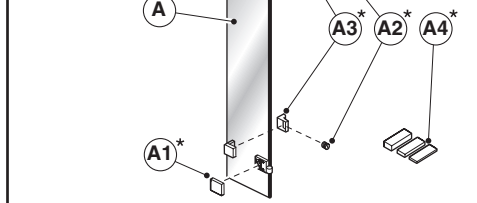

REF	DESCRIPTION	QTY
A	FIXED PANEL	1
A1*	HINGE COVER	2
A2*	GRUB SCREW	2
A3*	MOUNTING BRACKET COVER	2
A4*	ANTI-SLIP SHIM, 3mm, 2mm, 1mm 2 each	

SUPPORT BRACKET

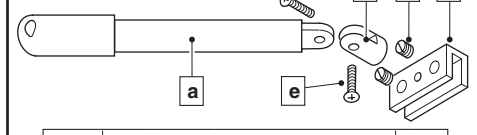

REF	DESCRIPTION	QTY
a	SUPPORT BRACKET ARM	1
b	'U' BRACKET	1
c	GRUB SCREW plastic	2
d	SWIVEL JOINT	1
e	FIXING SCREW	2

CURVED DOOR

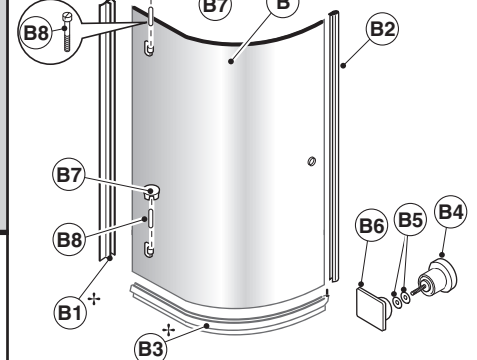

REF	DESCRIPTION	QTY
B	CURVED DOOR	1
B1+	INNER SEAL	1
B2	MAGNETIC SEAL	1
B3	DOOR BOTTOM SEAL	1
B4	DOOR HANDLE with threaded rod	1
B5	PLASTIC WASHER	2
B6	DOOR HANDLE outer	1
B7	HINGE PLUG	2
B8	ANTI-LIFT SCREW	2

+ Seals not compulsory in a wet room application for an improved aesthetic appearance

INLINE PANEL

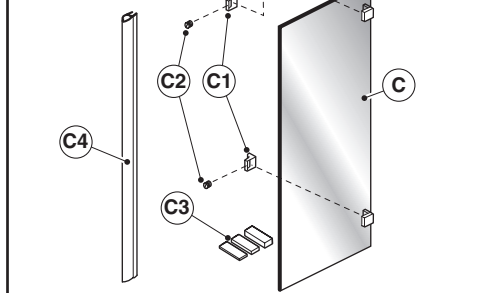

REF	DESCRIPTION	QTY
C	INLINE PANEL	1
C1	MOUNTING BRACKET COVER	2
C2	GRUB SCREW	2
C3	ANTI-SLIP SHIM, 3mm, 2mm, 1mm	1
C4	MAGNETIC SEAL	1

SEALING KIT-CURVED BAR

(NOT INCLUDED-Purchased separately)

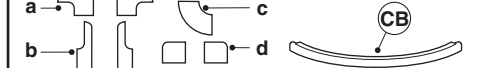

FRAMELESS SINGLE CURVED DOOR SHOWER ENCLOSURE

FULL FITTING INSTRUCTIONS FOR INSTALLATION IN A WET ROOM OR WITH A SHOWER TRAY

ALL NOMINAL DIMENSIONS IN MILLIMETRES

Please ensure that these instructions are read thoroughly prior to installation. The manufacturer cannot be held responsible for any problems arising from an incorrectly installed product.

TOOLS REQUIRED

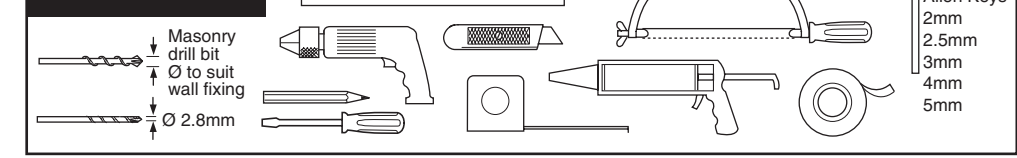

Guarantee Terms and Conditions

The Manufacturers policy is one of continuous development and improvement and accordingly we reserve the right to alter specification without prior notice.

The utmost care has been taken in the manufacture of this product to ensure it gives complete satisfaction. To the best of our knowledge this product was in perfect condition when it left our factory. You are recommended to examine it before installation and check quality, accuracy of the components and quantity of the contents. Customers should note that claims for damage to glass, finish or shortages must be submitted to the vendor before installation. The manufacturer also reserves the right to disallow claims once the product has been installed.

Failure to follow the recommendations set out in these instructions or to install in a manner not approved by the manufacturer may result in all or part of the product guarantee being null or void.

This product is guaranteed by the manufacturer for a period of 10 years from the date of purchase and no other proposal or statement by any other party will supersede or complement this offer. Should any part of it become defective due to faulty manufacture or materials, it will be replaced free of charge (supply only). Any parts supplied will have a guarantee term for the remaining period of the initial product guarantee stated previously. The product is not guaranteed against conditions of use or misuse.

This guarantee does not cover glass breakage however caused, or any fault arising from incorrect installation. Any replacement parts supplied, including assemblies, or completed products, are for DIY installation and no claim can be accepted for any costs however incurred for the installation of the replacement items.

This guarantee is offered as an extra benefit and is in addition to and does not affect your statutory rights. Please retain your receipt as proof of purchase.

Prior to installation, carefully unwrap the product; ensuring it is placed on a clean surface to reduce the risk of scratching the finish. Inspect the product for transit damage; all such damage must be reported within 3 days of receipt to the supplier.

INSTALLATION

The following text is to be read in conjunction with the pictorial diagrams. It is recommended that another person is available to assist with holding the assembly in place until the panels are fixed in position.

1 Ensure that a suitable shower base has been installed as per the manufacturer's instructions, that it is level and the joint between the tiles and the tray (if used) is sealed with a continuous bead of an appropriate sanitary silicone sealant. Ensure that the walls are tiled and are vertical to the base. Check that the minimum and maximum adjustments of this product correspond to the dimensions of the tiled opening.

2 FIXED PANEL

Measure **dimension A** along the wall from the inside corner and mark this position. Using a spirit level and a straight edge of suitable length, draw a perpendicular line up the wall from this position. From the original mark, draw a straight line at 90° to the wall the length of the fixed panel (**FP**).

Measure **dimension B** along the adjacent wall from the inside corner, and mark this position. Draw a perpendicular line up the wall from this position. From the original mark, draw a straight line at 90° to the wall the length of the inline panel (**IP**).

3 On the line marking the fixed panel, place two of the 3mm anti-slip shims (**A2**) onto the base at about 5mm over the pencil line towards the inside of the enclosure and approximately 100mm apart, central to the panel. Check the level across the shims. If the base is not level, it should be levelled using the 1mm and 2mm shims as necessary.

4 Lift the panel (**A**) into place with the **inside** edge against the drawn lines and mark through the holes in the brackets onto the wall.

5 Remove the panel, then drill the wall at the pre-marked positions and insert wall fixings applicable to your wall type construction (not supplied).

6 Replace the panel against the pencil lines. There should be a gap of about 2mm between the glass edge and the wall. Place a 2mm thick piece of packing at the top, check that the panel is at right angles to the base then place a packing piece at the bottom. Attach the panel to the wall using screws applicable to your wall fixings.

It is recommended that you apply a small bead of silicone sealant behind the head of each screw before tightening to prevent water ingress.

7 Remove the packing pieces. Check that the panel sits squarely to the base. If necessary adjustment can be made at each mounting bracket by slackening the fixing screws and carefully turning the hexagon head adjusting screws as required, with an allen key. When satisfied with the adjustment, tighten the fixing screws.

Further adjustment is available by slackening the large hexagon head screw in the glass side of the bracket.

Check that the panel is sitting level on the anti-slip shims on the base.

8 Place the cover caps (**A3**) on the mounting brackets. Secure with the grub screws (**A2**) using a 2mm allen key. Do not place the cover caps (**A1**) on the hinges at this point.

9 INLINE PANEL

If necessary, the inline panel may be changed from a right hand fit to a left hand fit, by rotating it through 180° so that the top becomes the bottom.

10 On the line marking the inline panel, place two of the 3mm anti-slip shims (**C3**) onto the base at about 5mm over the pencil line towards the inside of the enclosure and approximately 100mm in from the wall and the end of the inline panel. Check the level across the shims. If the base is not level, it should be adjusted using the 1mm and 2mm shims as necessary.

11 Lift the panel (**C**) into place with the **inside** edge against the drawn lines and mark through the holes in the brackets onto the wall.

12 Remove the panel, then drill the wall at the pre-marked positions and insert wall fixings applicable to your wall type construction (not supplied).

13 Replace the panel against the pencil lines. There should be a gap of about 2mm between the glass edge and the wall. Place a 2mm thick piece of packing at the top, check that the panel is at right angles to the base then place a packing piece at the bottom. Attach the panel to the wall using screws applicable to your wall fixings.

It is recommended that you apply a small bead of silicone sealant behind the head of each screw before tightening to prevent water ingress.

14 Remove the packing pieces. Check that the panel sits squarely to the base. If necessary adjustment can be made at each mounting bracket in the same method as adjusting the fixed panel (**stage 7**).

Check that the panel is sitting level on the anti-slip shims on the base.

15 Place the cover caps (**C1**) on the mounting brackets. Secure with the grub screws (**C2**) using a 2mm allen key. Push the magnetic seal (**C4**) onto the free edge of the inline panel.

16 CURVED DOOR

Note: The seals may be trimmed to length if required.

Push the bottom door seal (**B3**) into place with the peg at the opening edge (nearest to the inline panel) and the blade facing to the inside of the shower.

Push the magnetic seal (**B2**) onto the opening edge of the door, locating the bottom end onto the peg of the bottom seal. A small bead of clear silicone sealant may be placed at this joint before assembly.

The rear seal (**B1**) pushes onto the hinge end of the door with the blade facing the fixed panel.

17 Place one plastic base washer (**B5**) onto the threaded rod of the door handle (**B4**) and insert the rod through the hole in the glass of the door from the inside of the enclosure. Slide the second washer (**B5**) onto the threaded rod and screw into the square door handle (**B6**), ensuring that the handle is held squarely to the door with the 'tail' towards the fixed panel.

18 Using a 3mm allen key, slacken the two hexagon headed screws in the top of the door hinge to allow the plastic insert inside to rotate freely.

19 Lift the door and carefully place the hinges onto the hinges on the fixed panel. It may be necessary to 'jiggle' the door so that the hinges sit correctly in position with one another. There should be no gap at either hinge when in line with the fixed panel (in the closed position).

Tighten the two hexagon head screws and the anti-lift screw (**B8**) in the hinge and check the door operation. When opened either way it should rise on the hinges.

If preferred, the mating faces of the hinges may be coated with a suitable lubricant before assembly. If satisfied with the operation of the door, insert the blanking plugs (**B7**) in the top of the hinges.

20 Check the door alignment and operation. The bottom of the door glass should be about 18mm above the base (or tray rim). The top of the door should be in line with the fixed panel and the inline panel.

Adjustments can be made at the hinges on the fixed panel. If the door is out of line, slacken the two hexagon head screws in each hinge and re-align the door. Retighten all the adjusting screws.

21 If the door is level but above or below the fixed panel or inline panel, measure the difference between the two edges then place a piece of tape above or below the hinges on the fixed panel at that distance to be adjusted. It is recommended that the door is removed for this adjustment. Remove the plug (**B7**) from each hinge, unscrew the anti-lift

IMPORTANT

Take care to avoid hidden water pipes and electrical cables when drilling into the wall. Seek expert advice on the type of wall fixings applicable to your wall construction and the type of sealant to use in your application.

screw (**B8**) and carefully lift the door off.

Slacken the grub screw in the end of the hinge with a 2.5mm allen key. Slacken the hexagon head screw in the centre of the cam with a 5mm allen key. With a flat bladed screwdriver, rotate the cam until the hinge reaches the tape. Holding the cam in position with the screwdriver, tighten the centre screw with the allen key. Tighten the grub screw in the end.

22 Replace the door as in **step 19** and when satisfied with the alignment of the door, place the cover caps (**A1**) onto the hinges.

23 Trim the visible ends off the shims (**A4**, **C3**) on the inside and outside at the bottom of the fixed panel and inline panel.

24 SEALING THE ENCLOSURE

It is important that the shower enclosure is sealed properly and carefully to allow any water to flow back INTO the shower enclosure at the correct places. All surfaces must be clean and dry before the application of sealant.

The tray sealing kit is an additional product purchased separately if required.

Close the doors. Draw a line along the tray rim in line with the fixed panel parallel to the doors (approximately 19mm from the doors towards the outside of the enclosure).

Open the doors. Measure the distance between the edge of the fixed panel and the edge of the inline panel, in a straight line. Mark this measurement on the curved sealing bar (**CB**), measuring from the fixed panel end. Cut off the excess bar with a hacksaw.

25 Note: The kit includes left and right hand versions of end caps for different applications.

Select end caps **a** and **c** from the sealing kit. Apply a bead of silicone sealant inside each one and place them on the appropriate ends of the sealing bar (**CB**). Apply a run of sealant along the underside (flat) side of the sealing bar and another bead of sealant into the bottom edge of the fixed panel.

26 Push cap **a** against the edge of the fixed panel (the 'tongue' faces inside the enclosure).

Lay the sealing bar (**CB**) along the tray rim (or base) against the pencil line, up to the inline panel. When satisfied with the position of the bar, tape it to the base and leave until the sealant cures.

27 **1** Apply a continuous bead of clear silicone sealant on both the inside and outside from bottom to top between the wall and the fixed panel.

2 Apply a continuous bead of clear silicone sealant on both the inside and outside of the fixed panel along from the wall to the end cap (**a**) on the sealing bar.

3 Apply a continuous bead of clear silicone sealant on the **outside only** along the front edge of the sealing bar.

4 Apply a continuous bead of clear silicone sealant on both the inside and outside from bottom to top between the wall and the inline panel.

5 Apply a continuous bead of clear silicone sealant on both the inside and outside of the inline panel along from the wall to the end cap **c** on the sealing bar.

Allow 24 hours for the silicone sealant to fully cure before use.

SUPPORT BRACKET

A support bracket is used to provide greater rigidity to the side, in-line and fixed panels. For installation follow the instructions on the back page.

TROUBLE SHOOTING

Door does not close square or securely

- Ensure the tray is level and 90° to the walls
- Check that the enclosure is vertical
- Ensure that no excess silicone or debris is blocking door closure

PREPARATION

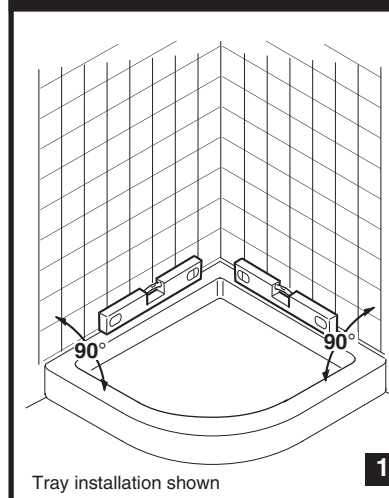

Tray installation shown

FIXED PANEL

INSTALLATION DIMENSIONS

PANEL SIZE	A to Fixed Panel	B to Inline Panel
900	866	846

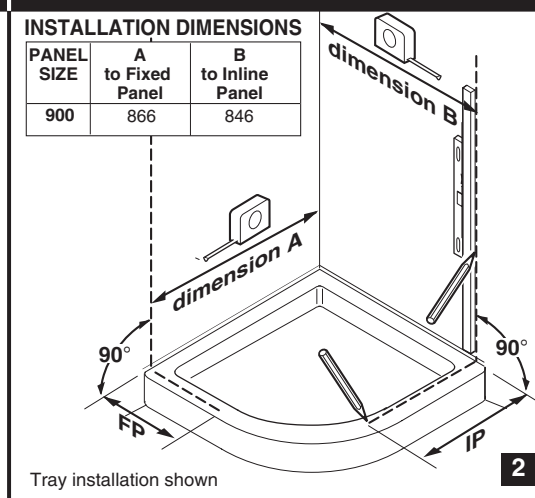

Tray installation shown

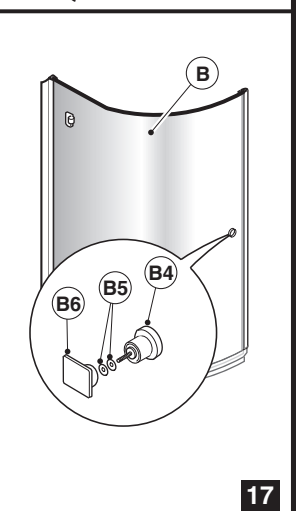
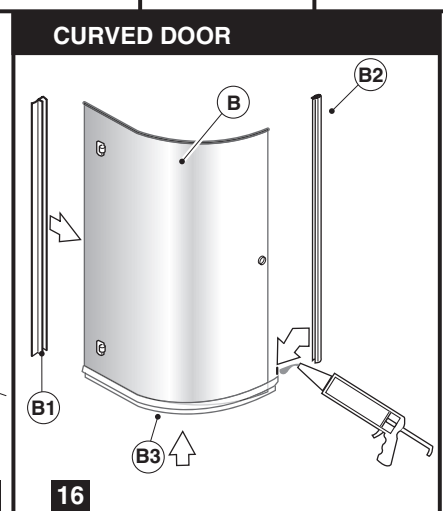
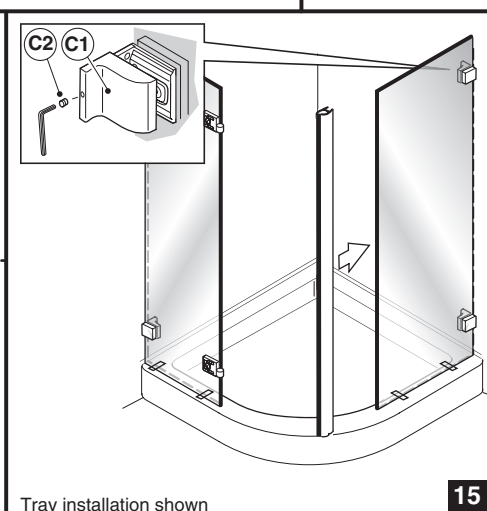
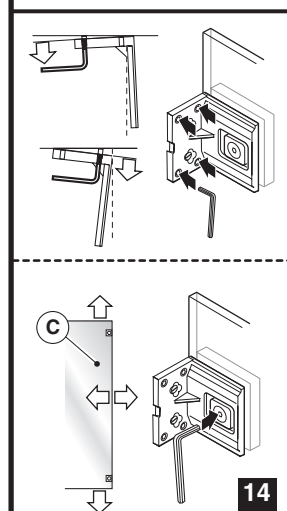
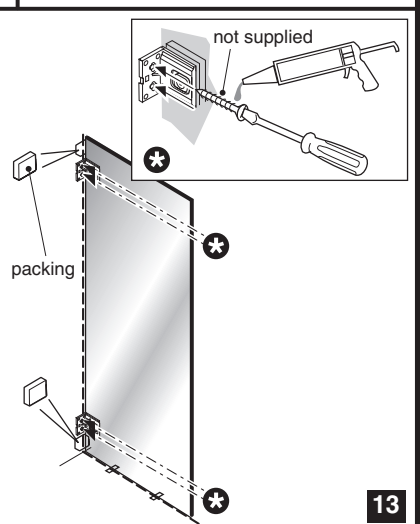
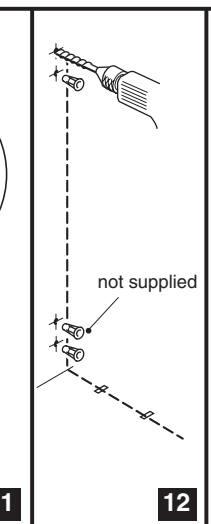
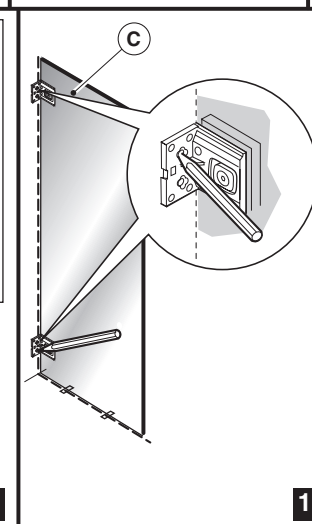
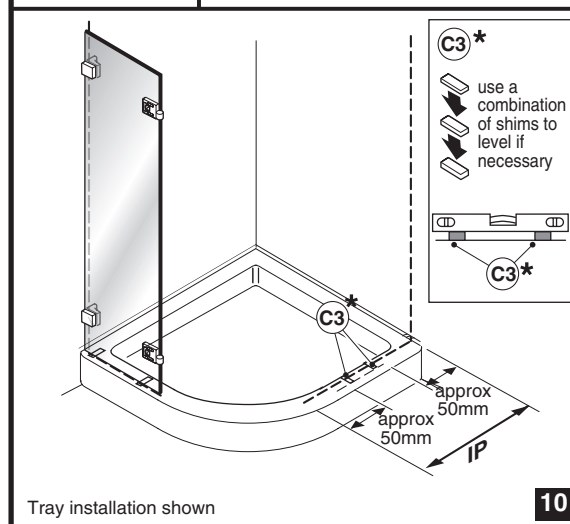
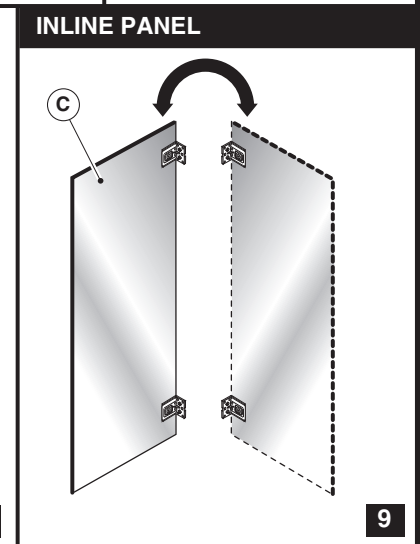
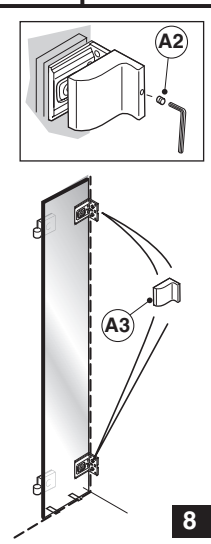
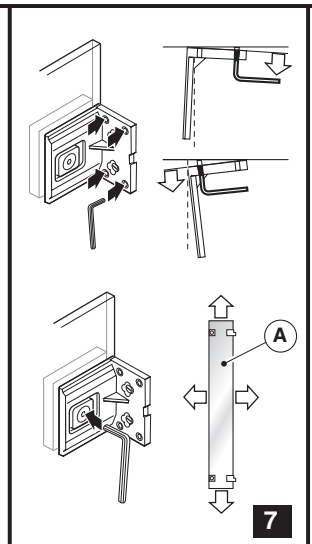
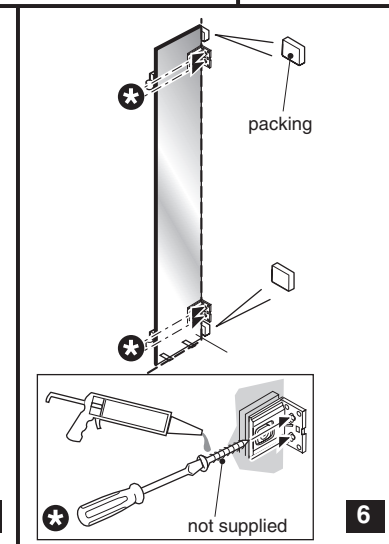
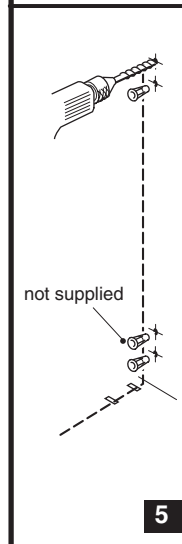
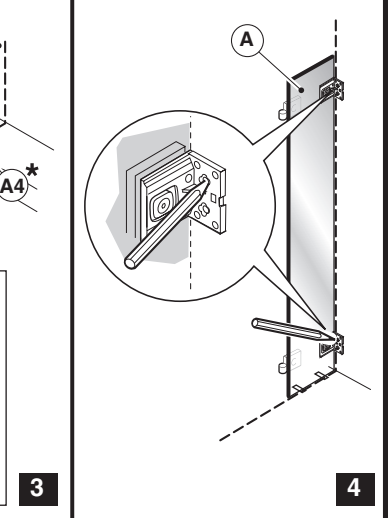
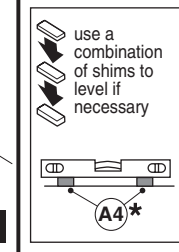
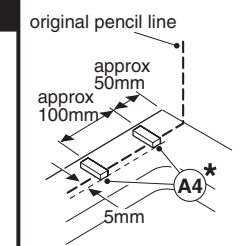

continued at top of next column ▲

continued overleaf ▶